

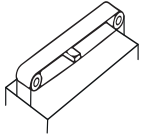



## TRIZACT 337 DC

Produktdaten <i>product data</i>	Grammatur <i>weight</i>	Unterlage <i>backing</i>	Bindung <i>bonding</i>	Streuerung <i>coating</i>	Kornart <i>abrasive</i>
	/	X-Polyestergewebe	Harzbindung	replizierte Struktur	Aluminiumoxid

Körnungs- bereich <i>grits</i>	12 16 24 36 40 50 60 80 100 <b>120</b> 150 180 220 240 280 320 360 400 500 600 800 1000 1200 2500
	<b>A160</b>

Produkte <i>standard forms</i>	Breitband <i>wide belts</i>	Langband <i>long belts</i>	Kurzband <i>short belts</i>	Rolle <i>rolls</i>	Bogen <i>sheets</i>	Scheibe <i>discs</i>
						
Anwendung <i>applications</i>	<ul style="list-style-type: none"> <li>✓ Stahl</li> <li>✓ Edelstahl</li> <li>✓ NE-Metalle</li> </ul> <ul style="list-style-type: none"> <li>✓ Aluminium</li> </ul>					

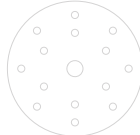
Eigenschaften <i>features</i>	Fertigungsbreite <i>maximum width</i>	Farbe vorne <i>main color front</i>	Farbe Rückseite <i>color backing</i>	Aufdruck <i>printing</i>
	610 mm	chamois	chamois	3M Trizact CF 337DC

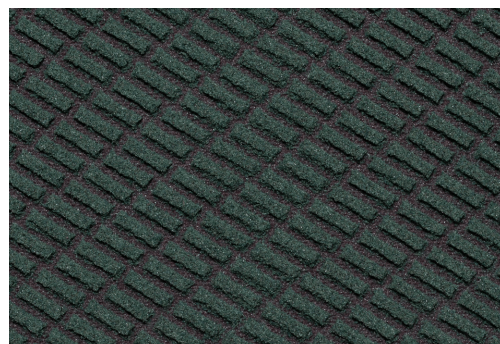

Das 3M Trizact Gewebeschleifband 337 DC ist ein strukturiertes Langzeitschleifwerkzeug für die Bearbeitung hochlegierter Metalle. Die einzelnen Mineralschichten der Quaderstruktur regenerieren sich kontinuierlich während des gesamten Schleifprozesses und erzeugen somit eine gleichmäßige, reproduzierbare Oberfläche.

